

© lersé design

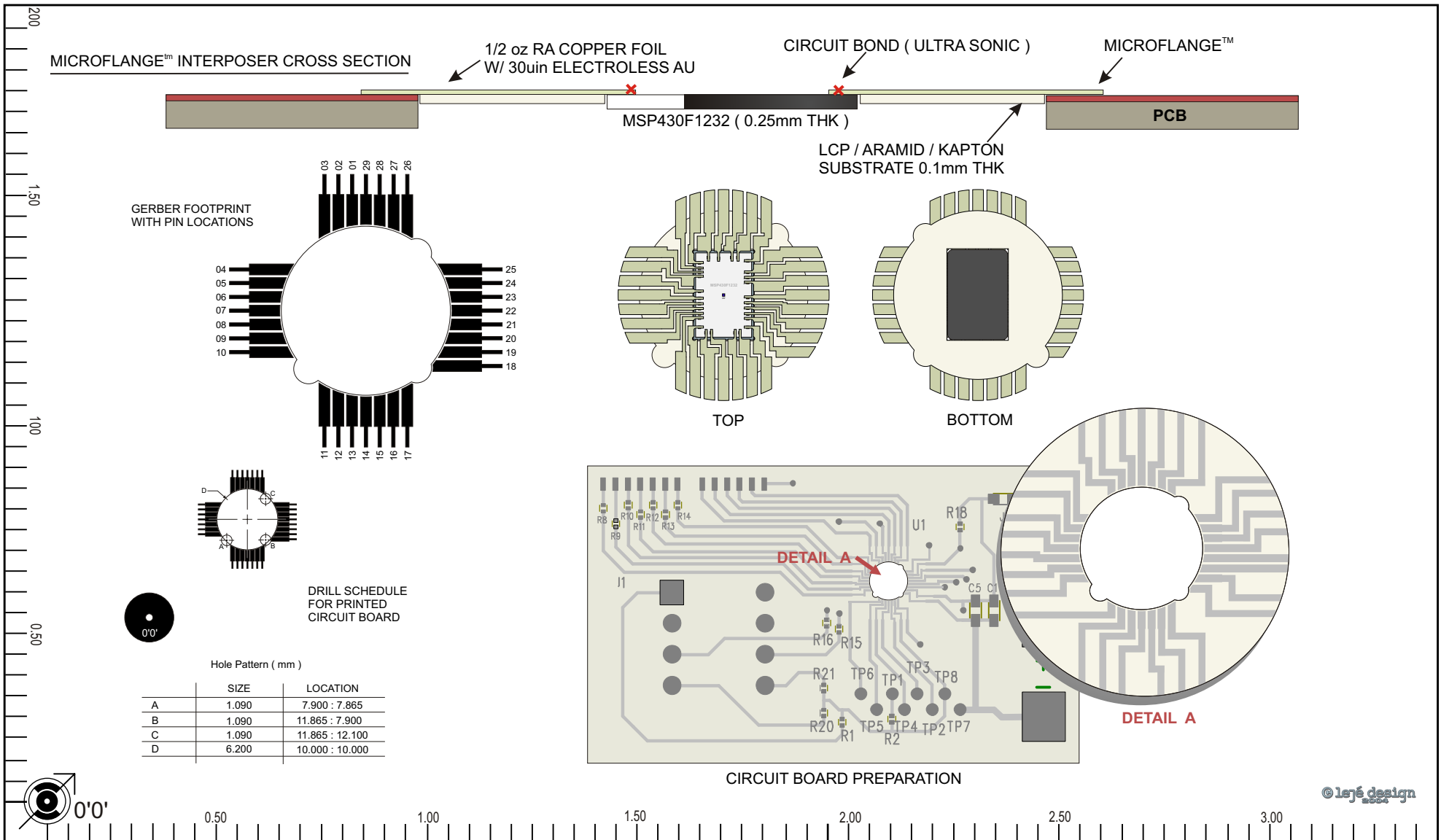

DOCUMENT NO.
DL-322B
4604

MICROFLANGE™ DEVICE - GENERAL FEATURE

MicroSite™

IntraGlobal.net
PO Box 500037 Atlanta GA 31150
770 390 0203 www.intraglobal.net

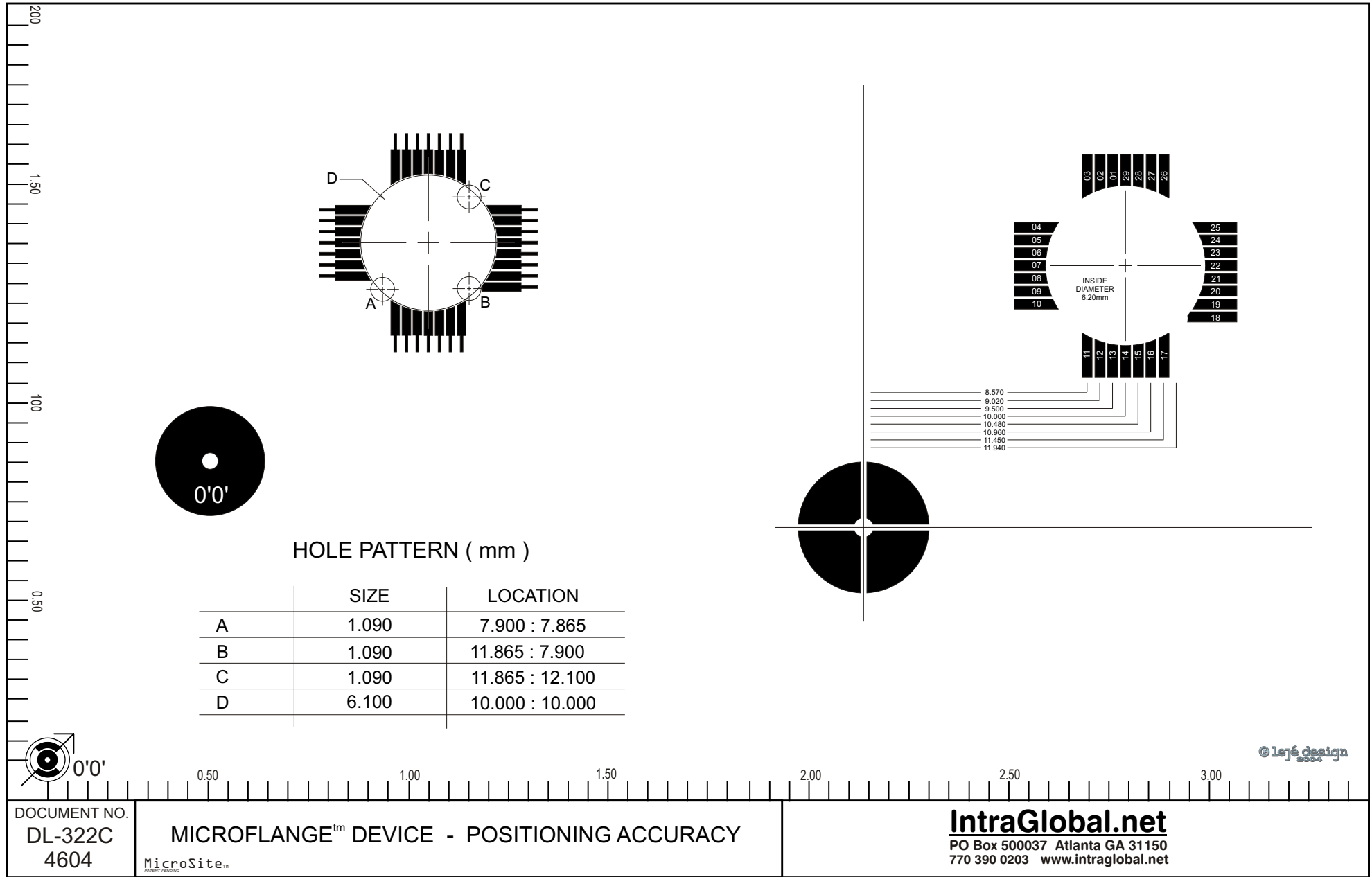

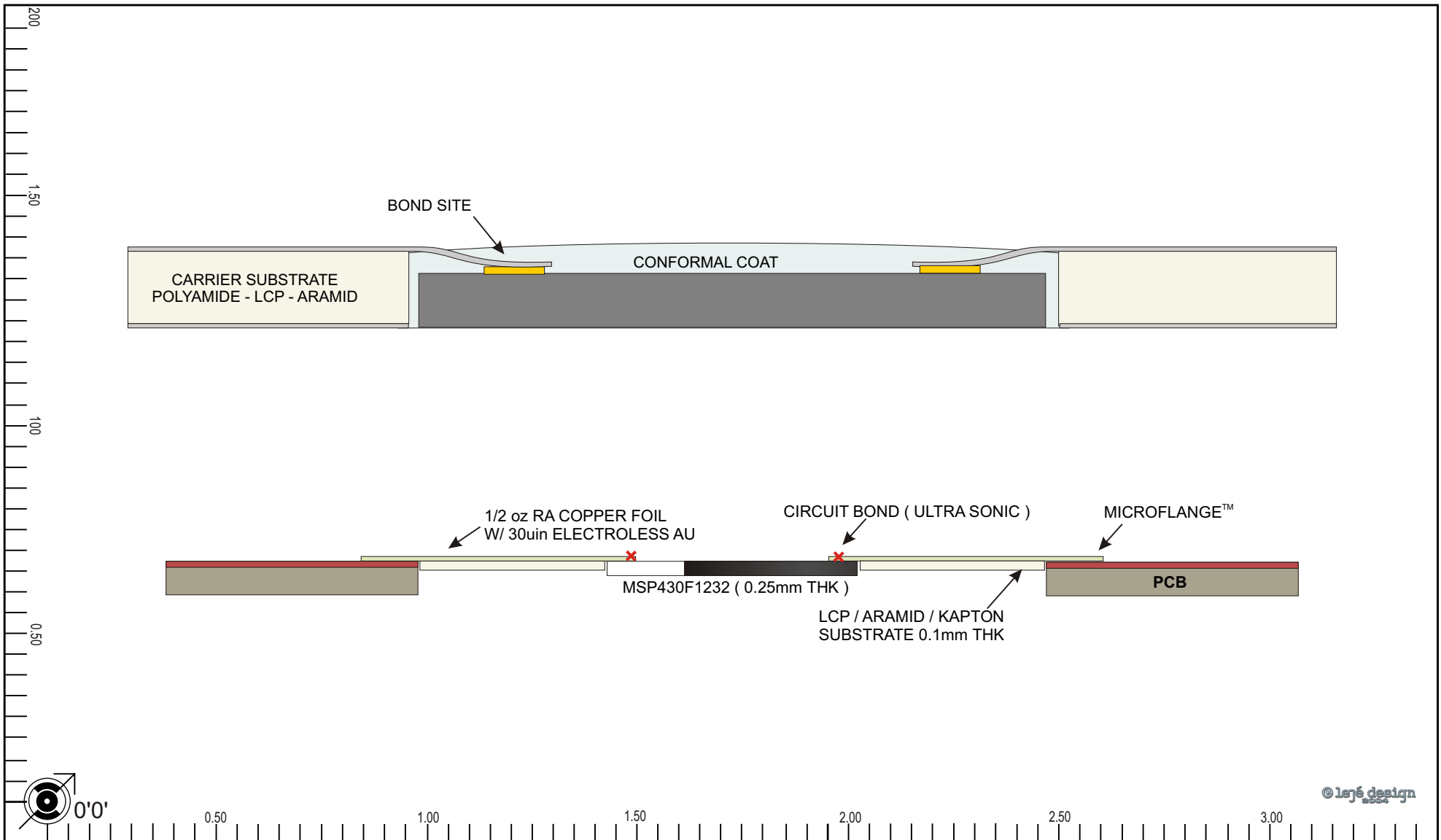

DOCUMENT NO.
DL-322D
4604

MICROFLANGE™ INTERPOSER CROSS SECTION

IntraGlobal.net
PO Box 500037 Atlanta GA 31150
770 390 0203 www.intraglobal.net

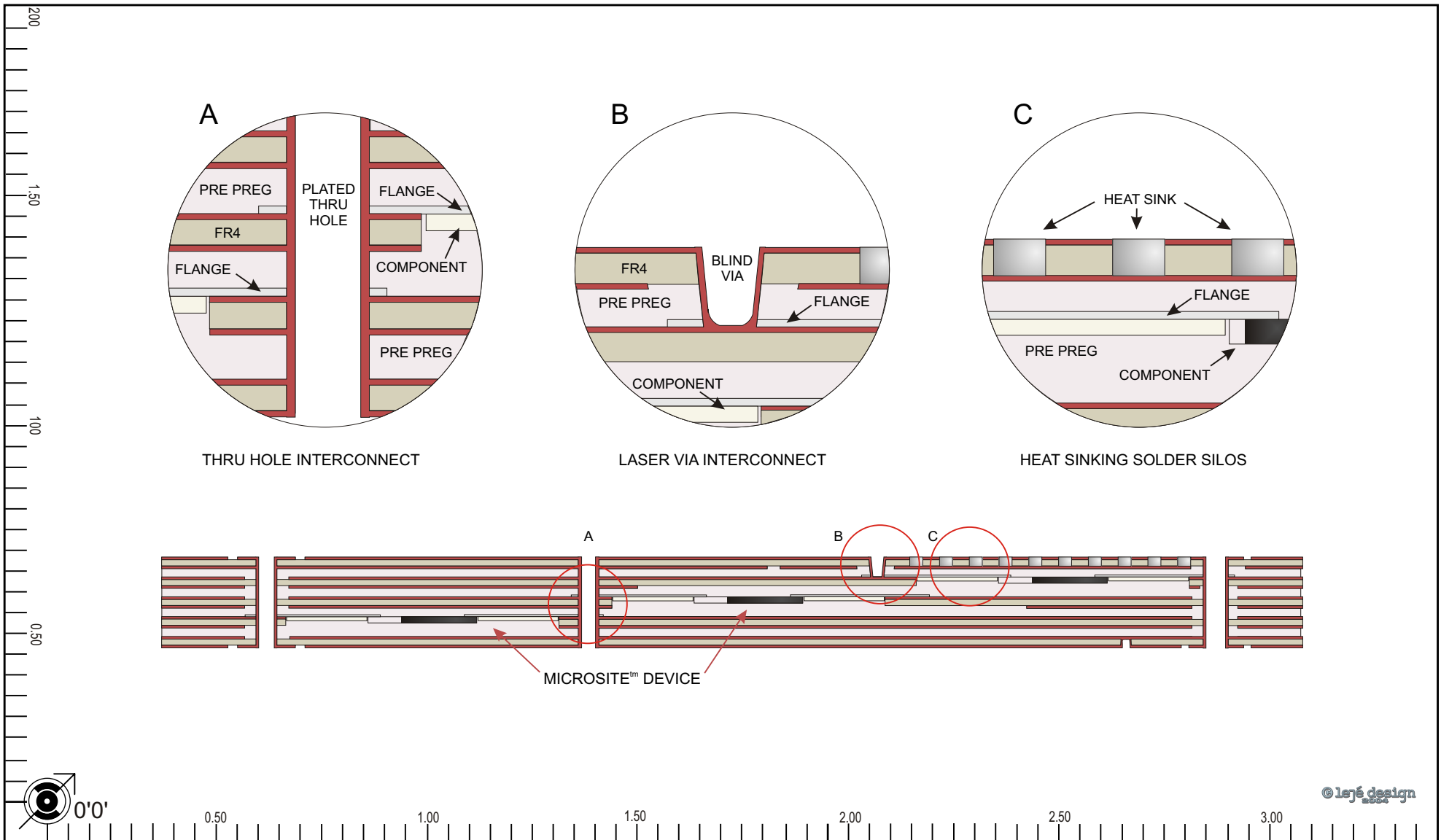

© lersé design

DOCUMENT NO.
 DL-322E
 4604

MICROFLANGE™ DEVICE - LAMINATING DETAIL

MicroSite™

IntraGlobal.net
 PO Box 500037 Atlanta GA 31150
 770 390 0203 www.intraglobal.net

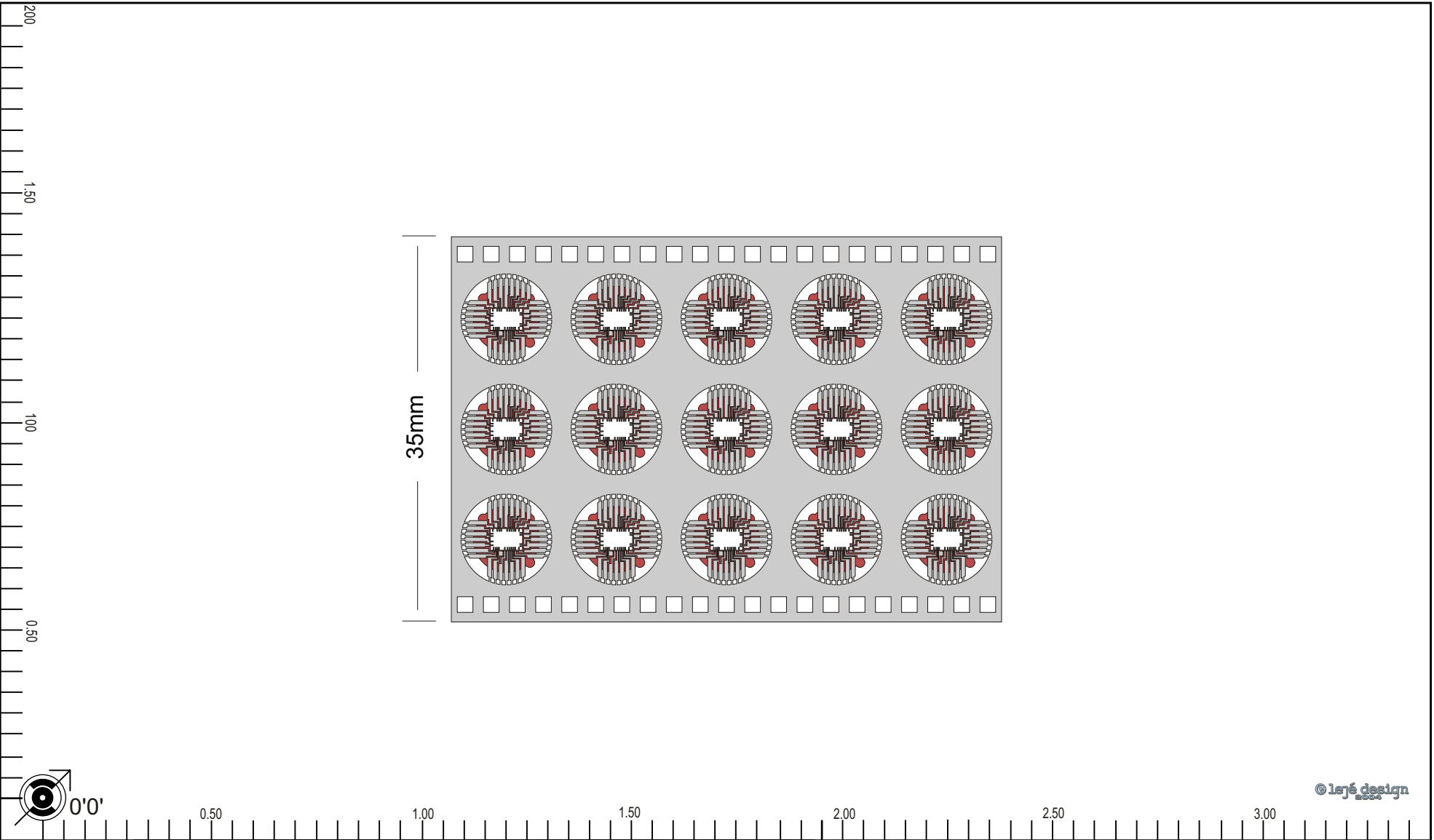

© leje design

DOCUMENT NO.
DL-322F
4604

MICROFLANGE™ DEVICE - MANUFACTURING FORMAT

MicroSite™

IntraGlobal.net

PO Box 500037 Atlanta GA 31150
770 390 0203 www.intraglobal.net

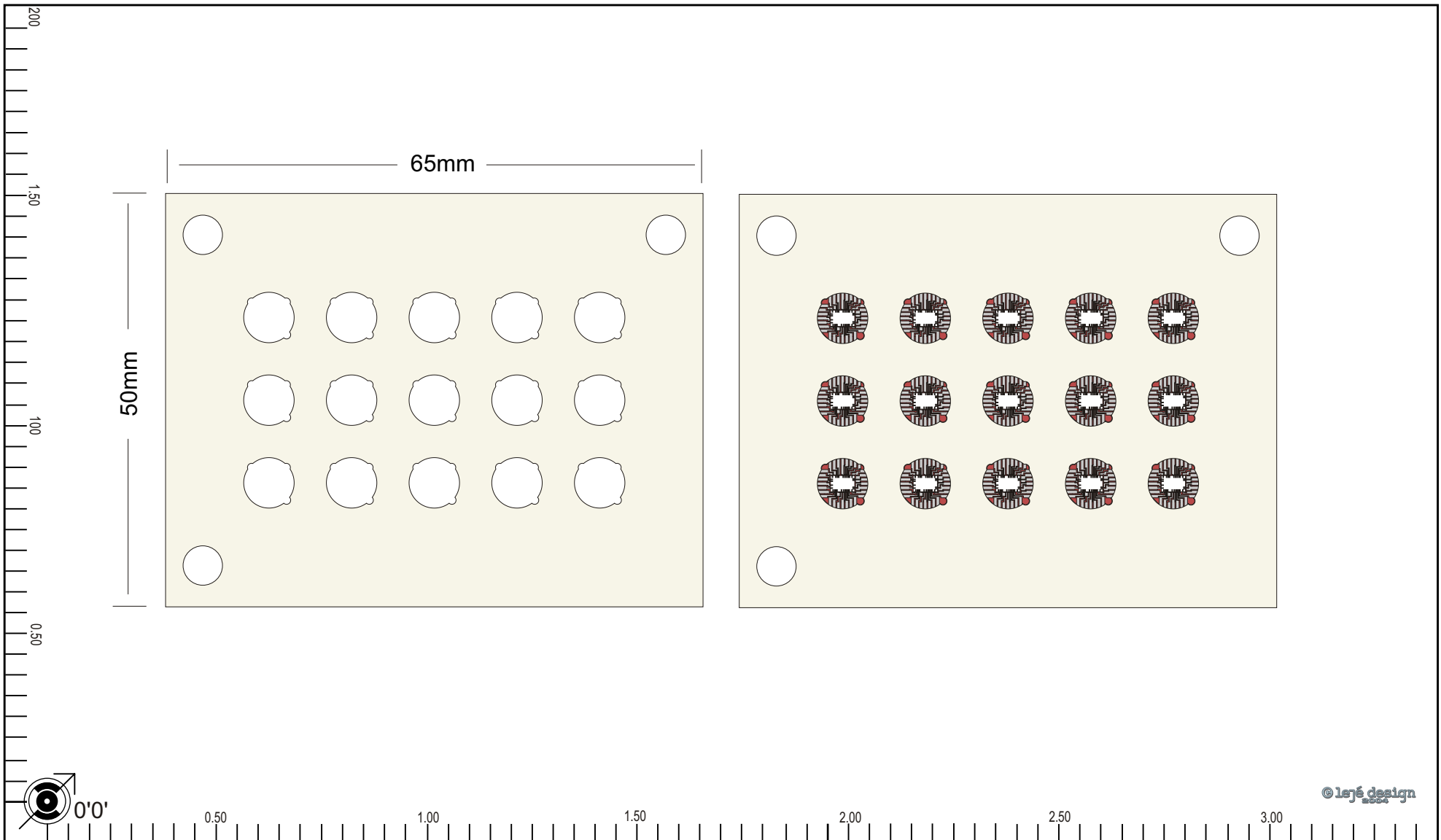

© leje design

DOCUMENT NO.
DL-322G
4604

MICROFLANGE™ DEVICE - ASSEMBLY CASSETTE

MicroSite™

IntraGlobal.net
PO Box 500037 Atlanta GA 31150
770 390 0203 www.intraglobal.net